

BALL VALVES INTEC

Stem extension double-sealed
cryogenic type
INTEC 12-S-TT

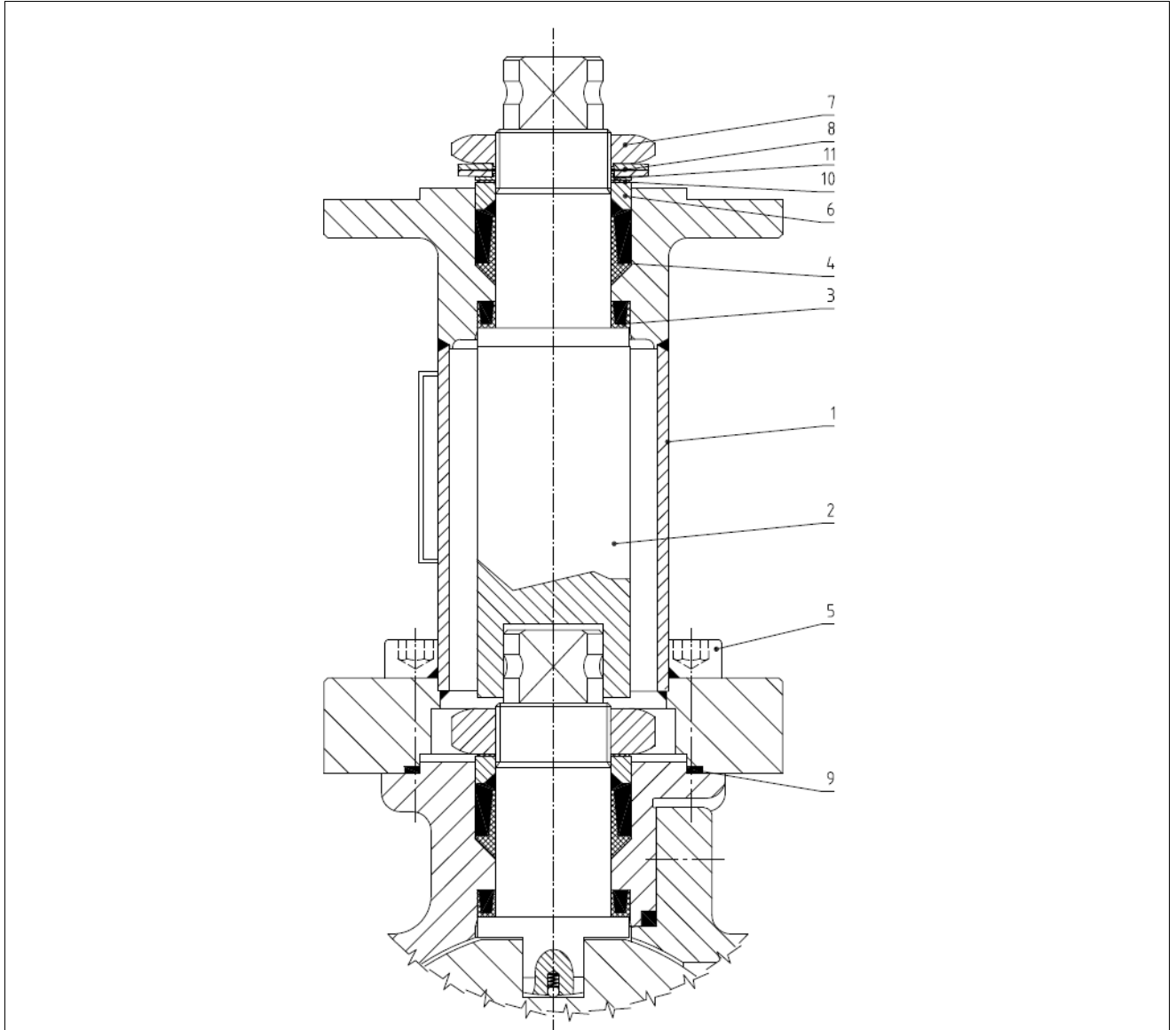

No.	Part	Material
1	body	1.4571/1.4404
2	coupling	1.4462/1.4980
3	below seal	KFGN/Graphite
4	upper seal	KFAM/Graphite
5	socket screw	A2-70/1.4980
6	thrust ring	1.4571/1.4404
7	hex. nut self-locking	A2/1.4301
8	disc spring	1.4568
9	body seal (stem extension)	Graphite
10	thrust washer	PEEK
11	thrust ring	1.4571/1.4404